

Heat Generators and Recovery Dehumidifiers

HRDe/HGMD Application Guide

Relative Humidity Control

ACMV P L

(Singapore)

HRDe/HGMD Model PR

- HRDe/HGMD PR model is a self contain packaged unit installed right at the air conditioned room or non -air conditioned spaces and operate to reduce air moisture. This unit is applicable at work-places where there is a need of lower relative humidity either for comfort or by process application. It can also be used to dry grains, fruits, dry clothes in laundry, reduces moisture in kitchens and for dry chemical storage.

A. Rooms with independent air conditioning

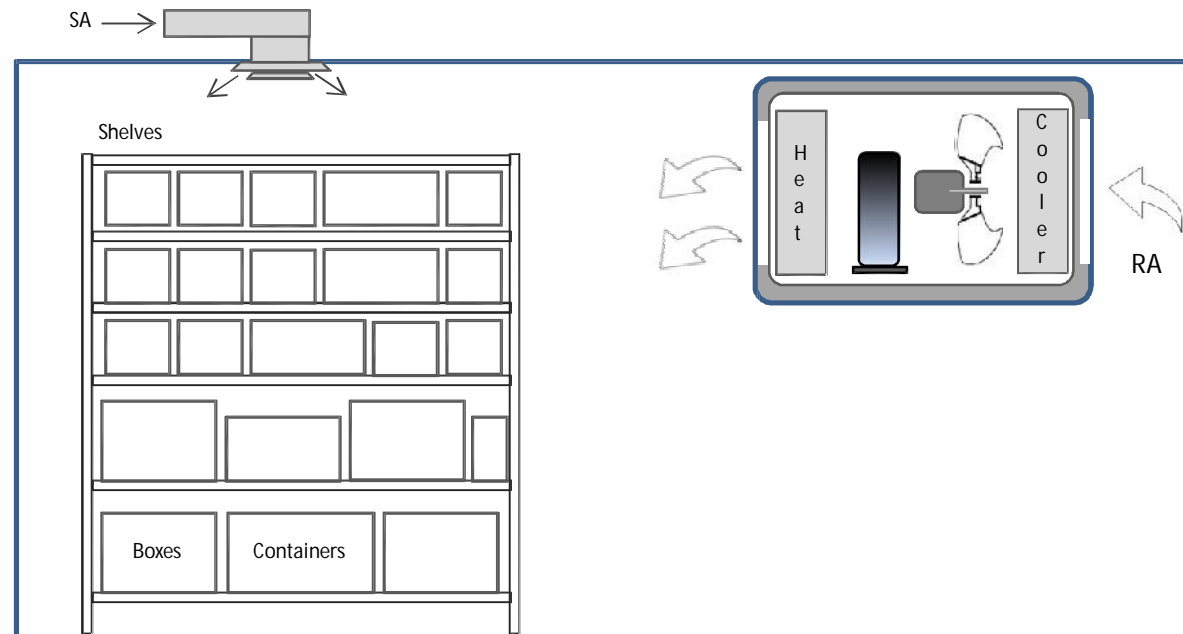

HRDe/HGMD Model PR

- HRDe/HGMD PR model can also be installed on the room walls to precool and dehumidify outside air and supply directly into the room. This is applicable to spaces or storage rooms that require lower humidity than its surroundings.

B. Rooms with or without independent air conditioning

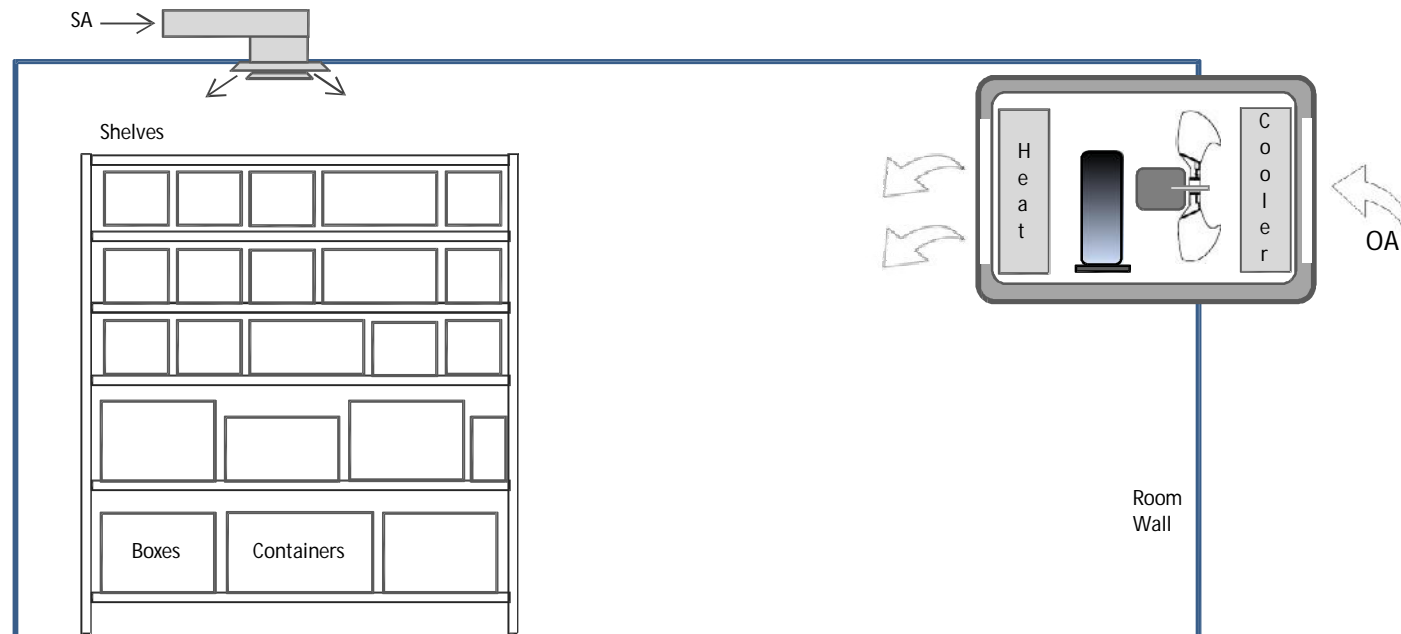

HRDe/HGMD Model PNR

- HRDe/HGMD Model PNR is designed as a self-contained packaged air-cooled units to serve multiple fan coil units fitted with pre-cool or post-cool and reheat coils to cool spaces and control relative humidity. Supplied with built-in water recirculating pumps with capacity range from 1 to 45 kW and designed to supply chilled water to precool or post-cool air and warm to hot water use as reheat to control Relative Humidity. The system is designed for application where Institutions restricts the use of direct cooling system where refrigerant may leak into the air stream and affect indoor air quality. Gas leakage include oil mist that would become of greater concern in wound treatment, surgery or operating theaters. Control range of Relative Humidity is 60 to 30% with space temperatures from 18 to 24°C. Hot water maximum temperature is 60°C.

APPLICABLE for No-Refrigerant on Air Stream Requirements as per ASHRAE 15 guidelines

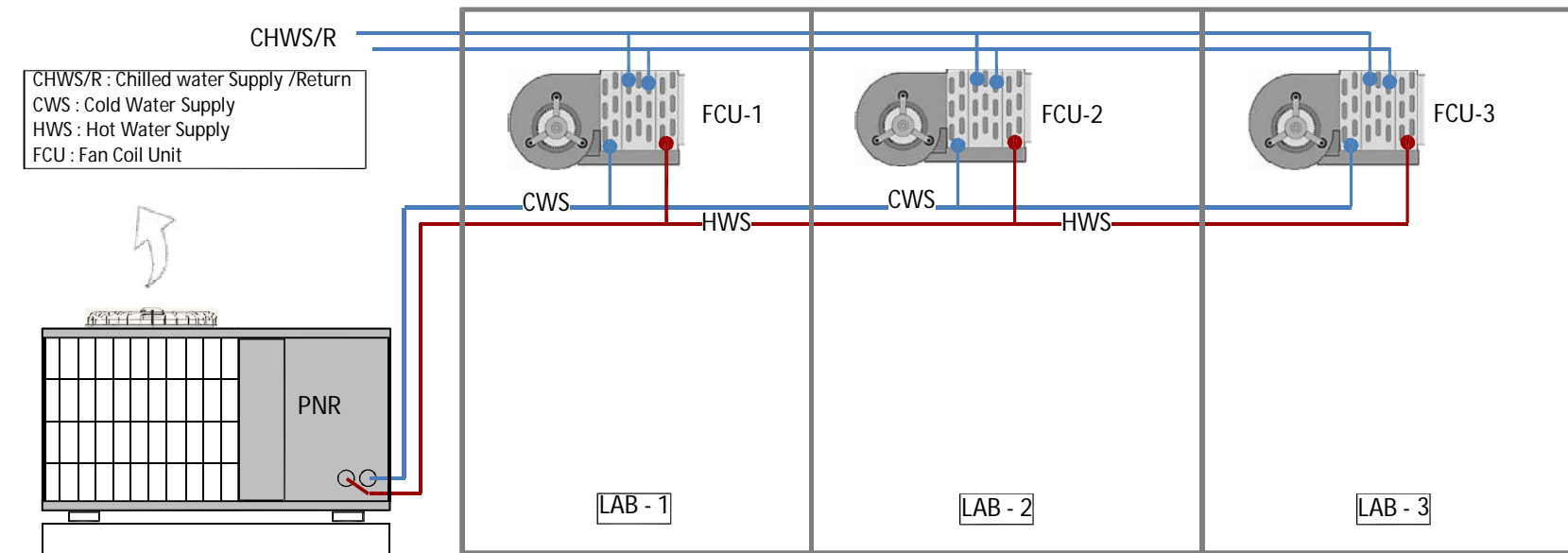

HRDe/HGMD Model AR

- HRDe/HGMD Model AR are custom built heat recovery system design according to the of Air Handling Units requirements. The HRDe/HGMD unit can be supplied with DX and Reheat Coils and comes complete with compressor, refrigeration piping and controls and are field installed normally at proximity to the AHU. This model has capacity range of 6 to 50 kW for small to medium AHU up to 51 kW and above for AHU up to 100,000 cmh air flow. Relative Humidity control range from 60 to 40% with space temperatures from 18 to 24°C. This system is NOT APPLICABLE to Institutions with restrictions of refrigerant on air in the event there is a system gas leakage as per ASHRAE 15 guidelines.

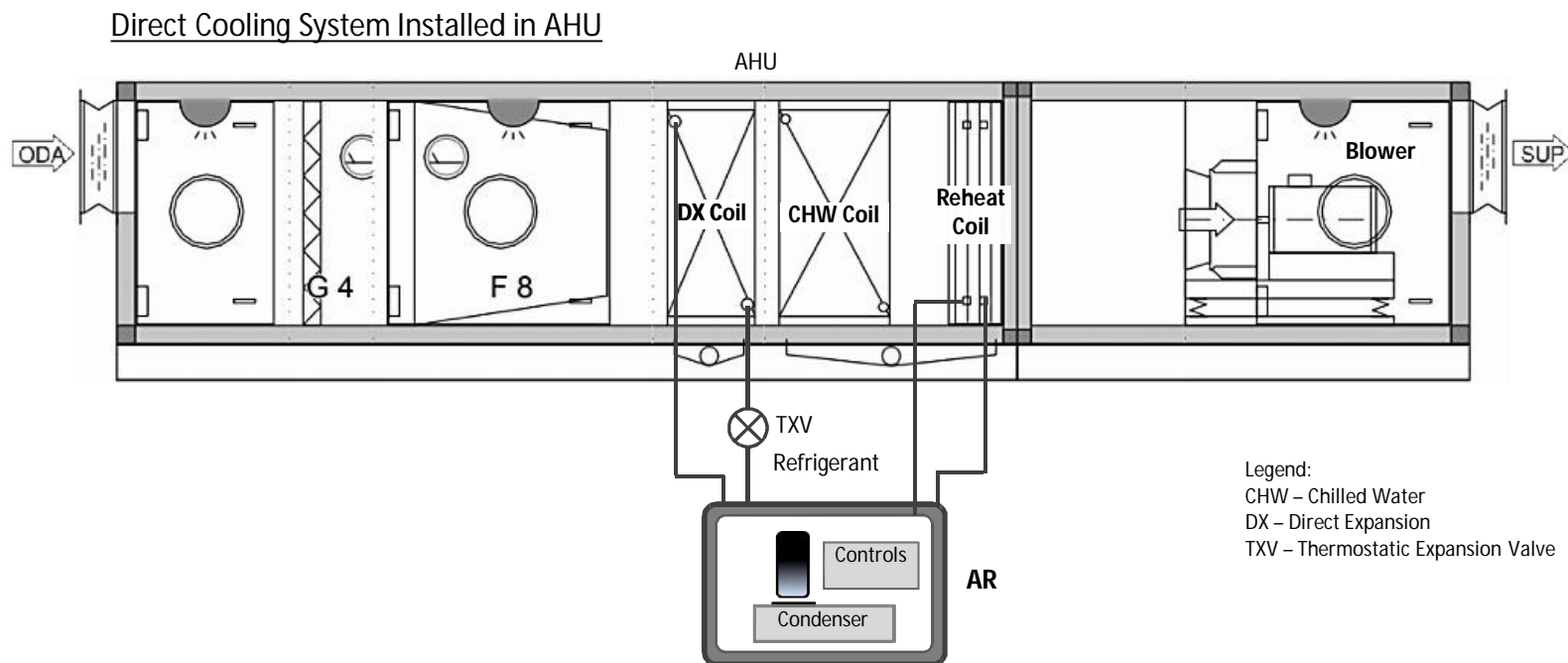

HRDe/HGMD Model AR

- HRDe/HGMD Model AR are custom built heat recovery system design according to the of Air Handling Units requirements. The HRDe/HGMD unit can be supplied with DX and Reheat Coils and comes complete with compressor, refrigeration piping and controls and are field installed normally at proximity to the AHU. This model has capacity range of 6 to 50 kW for small to medium AHU up to 51 kW and above for AHU up to 100,000 cmh air flow. Relative Humidity control range from 60 to 40% with space temperatures from 18 to 24°C. This system is NOT APPLICABLE to Institutions with restrictions of refrigerant on air in the event there is a system gas leakage as per ASHRAE 15 guidelines.

Direct Cooling System Installed OUTSIDE AHU : this application is for RETROFITTING existing AHU that is no space for the additional coils.

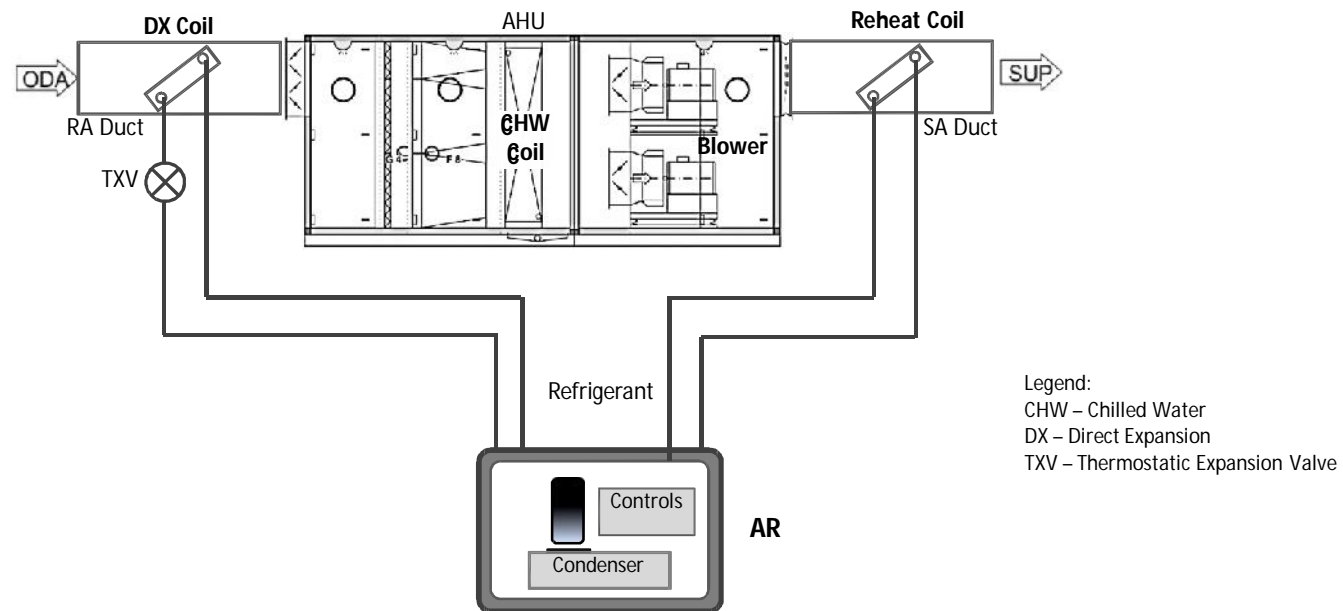

HRDe/HGMD Model ANR

- HRDe/HGMD Model ANR is a custom built heat recovery system designed as per Air Handling Units requirements. The HRDe/HGMD can be supplied complete with CHW coil, CW and Reheat Coils and comes complete with compressor, refrigeration piping, recirculating pumps and controls and are field installed normally next or proximity to the AHU. This model has capacity range of 5 to 500 kW for AHU up to 100,000 cmh. This system is APPLICABLE to Institutions with restrictions of refrigerant on air in the event there is a system gas leakage. Gas leakage include oil mist that would become of greater concern in wound treatment, surgery or operating theaters. Relative Humidity range 60 to 30% with space temperatures from 18 to 24°C.

APPLICABLE for No-Refrigerant on Air Stream Requirements as per ASHRAE 15

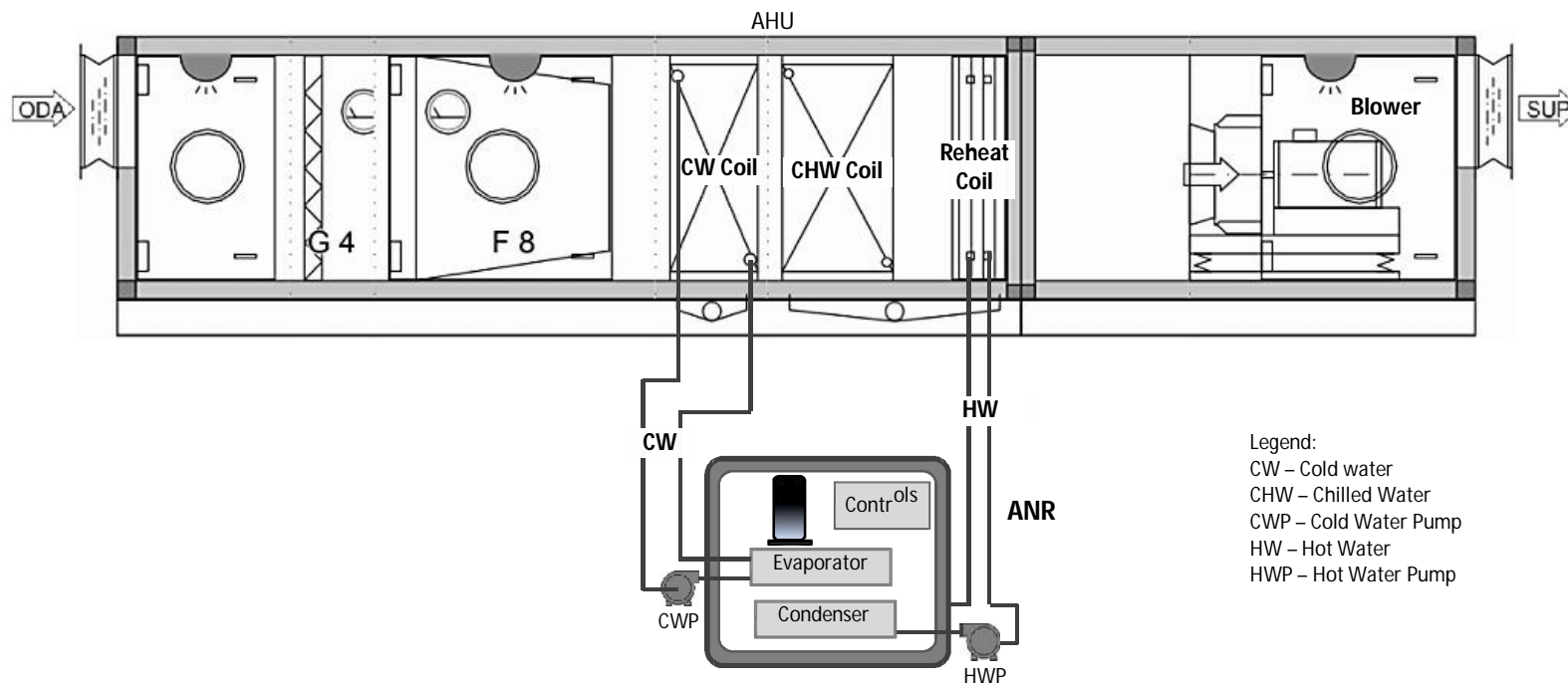

HRDe/HGMD Model ANR

- HRDe/HGMD Model ANR is a custom built heat recovery system designed as per Air Handling Units requirements. The HRDe/HGMD can be supplied complete with CHW coil, CW and Reheat Coils and comes complete with compressor, refrigeration piping, recirculating pumps and controls and are field installed normally next or proximity to the AHU. This model has capacity range of 5 to 500 kW for AHU up to 100,000 cmh. This system is APPLICABLE to Institutions with restrictions of refrigerant on air in the event there is a system gas leakage. Gas leakage include oil mist that would become of greater concern in wound treatment, surgery or operating theaters. Relative Humidity range 60 to 30% with space temperatures from 18 to 24°C.

Chilled Water Pre-cooling and Reheat Coils installed OUTSIDE AHU : this ANR application is suitable for RETROFITTING of existing AHU's if there is not enough space in the AHU for the additional coils. Applicable for No-Refrigerant on Air Stream Requirements per ASHRAE 15.

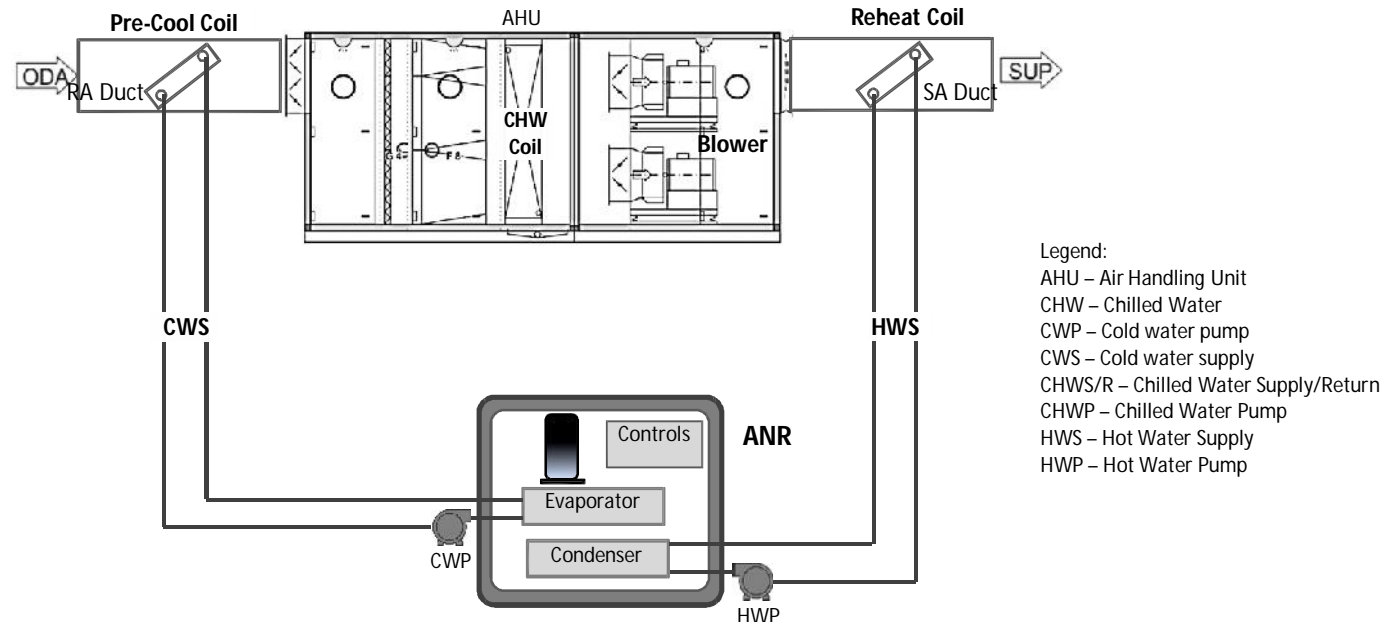

HRDe/HGMD Model ANR

- HRDe/HGMD Model ANR is a custom built heat recovery system designed as per Air Handling Units requirements. The HRDe/HGMD can be supplied complete with CHW coil, CW and Reheat Coils and comes complete with compressor, refrigeration piping, recirculating pumps and controls and are field installed normally next or proximity to the AHU. This model has capacity range of 5 to 500 kW for AHU up to 100,000 cmh. This system is APPLICABLE to Institutions and laboratories with restrictions of refrigerant on air in the event there is a system gas leakage. Gas leakage may include oil mist that would become of greater concern in wound treatment, surgery or operating theaters and experiments. Relative Humidity range 60 to 30% with space temperatures from 18 to 24°C.

CHWS is cooled down and Reheat Coils installed OUTSIDE AHU : this ANR application is suitable for RETROFITTING if there is not enough space in the AHU for the additional coils and the CHWS temperature is not low enough to achieve dew point temperatures required. Applicable for No-Refrigerant on Air Stream Requirements per ASHRAE 15.

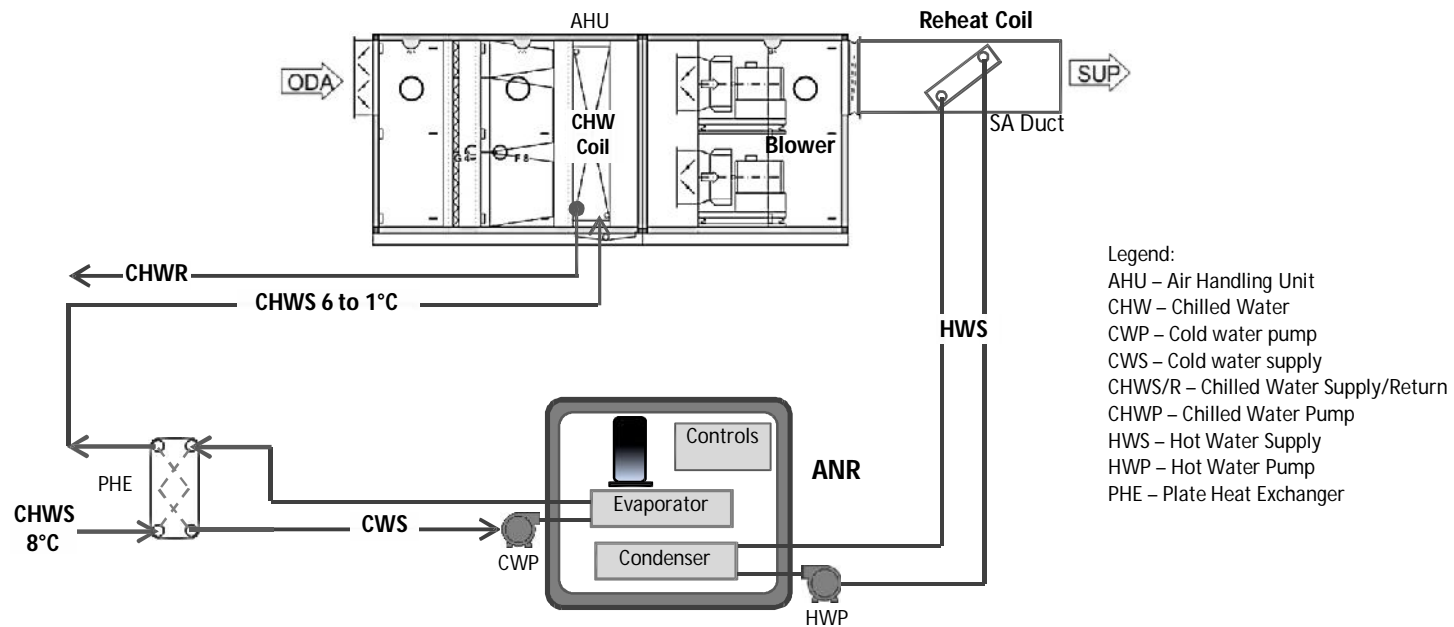

HRDe/HGMD MODEL ANR (Packaged w/ AHU)

HRDe/HGMD Model ANR is a custom built heat recovery system designed and packaged with Air Handling Units requirements. The HRDe/HGMD can be supplied complete with CHW coil, CW and Reheat Coils and comes complete with compressor, refrigeration piping, recirculating pumps and controls and are field installed normally next or proximity to the AHU. This model has capacity range of 5 to 500 kW for AHU up to 100,000 cmh. This system is Applicable to Institutions and laboratories with restrictions of refrigerant on air in the event there is a system gas leakage. Gas leakage may include oil mist that would become of greater concern in wound treatment ,surgery or operating theatres and experiments. relative Humidity range 60 to 30% with space temperatures from 18 to 24°C are achievable.

CHWS is cooled down and Reheat Coils installed inside the AHU : this ANR application is suitable for integrated in the AHU and the CHWS temperature is not low enough to achieve dew point temperatures required. Applicable for No-Refrigerant on Air Stream Requirements per ASHRAE 15.

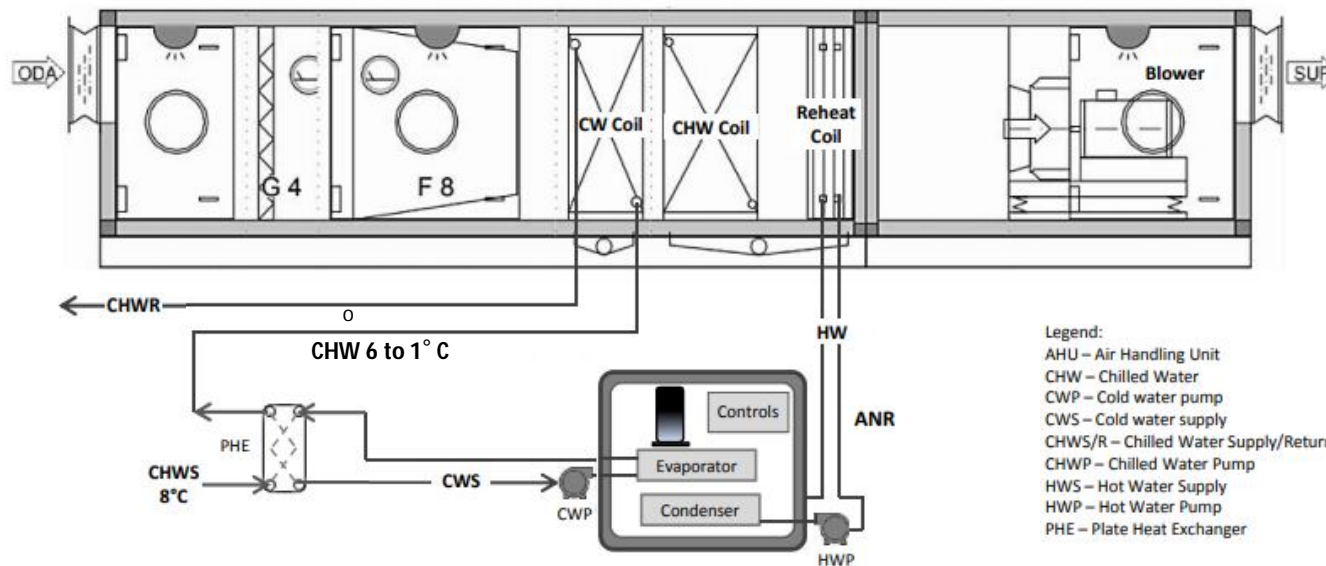

HRDe/HGMD Model GNR

- HRDe/HGMD GNR model is a wide capacity range packaged chilled and hot water generators. The chilled water generated can be used to cool the main chilled water supply or directly use to cool spaces and even cooling Condenser water to save energy. Built-in recirculating pumps are optional. GNR are applied to supply hot water to multiple or single large AHU's to control Relative Humidity of conditioned spaces. Hot water can also be supplied to essential building services like hotel laundry, hot shower system, pre-heating boiler feed water, kitchen and laboratories. GNR capacity range 50 to 500 kW and multiple units up to 2000 kW.

APPLICABLE for No-Refrigerant on Air Stream Requirements as per ASHRAE 15

