



# ACMV MAGLEV CHILLER



**25%-40%**  
Energy conservation

# CONTENTS

---



<b>Introduction</b>	<b>01</b>
<b>Technology Features</b>	<b>02</b>
<b>Advantage</b>	<b>03</b>
<b>Technical Data</b>	<b>04</b>
<b>Job References</b>	<b>05</b>
<b>Water Management</b>	<b>06</b>
<b>About Us</b>	<b>07</b>

# INTRODUCTION

## **ACMV Pte. Ltd.**

In today's rapidly evolving industrial and commercial landscape, efficient cooling systems are essential for ensuring operational reliability, energy efficiency, and environmental sustainability. As specialist in chiller manufacturing, we take pride in delivering high-performance cooling solutions that meet the diverse needs of our clients across multiple industries.

With years of experience and technical excellence, our team specializes in the design, engineering, and production of advanced chiller systems. Our expertise covers a wide range of applications, including HVAC systems, industrial process cooling, data centers, and specialized temperature control environments. We understand that every project has unique requirements, and we are committed to providing customized solutions that optimize performance while minimizing energy consumption.

Our manufacturing process is built on precision, innovation, and quality assurance. From selecting premium-grade components to implementing rigorous testing procedures, we ensure that every chiller unit meets international standards and delivers long-term reliability. By integrating cutting-edge technologies such as energy-efficient compressors, smart control systems, and environmentally friendly refrigerants, we help our clients reduce operational costs and carbon footprint.

## Technology Feature

ACMV Maglev chillers utilize oil free chiller technology with Raetts compressors using R134a and R1234ze refrigerant. ACMV Maglev Chillers are available from 65 to 900TR and can be supplied in multiple configurations, which ACMV Maglev can customize per the requirements of your application.

Oil-free centrifugal chillers use magnetic bearings and a variable speed drive to deliver IPLV efficiencies that far surpass those of conventional oil-lubricated centrifugal, reciprocating, scroll and screw chillers. ACMV Maglev utilizes totally oil-free Raetts compressor technology, achieving the highest part-load efficiencies for our chillers and chilled water systems



### Magnetic Levitation Bearing Direct Drive - Revolutionizing Traditional Technology

Motor efficiency >96%

Load adjustment 10-100%

Zero Friction, Lubricating Oil

Noise <70 dB (A)

Starting current 2A

The service life is up to 30 years

Higher comprehensive efficiency



**IPLV up to 11.58**      **COP up to 7.2**

# Maglev Chiller

## Five core advantages



01 Oil-free design,  
low noise and environmental  
protection



02 2 Amps low-current  
startup



Only 2A of electricity is needed to start (traditional chillers require 500-600A of electricity), which can reduce the maximum power load, avoids grid shocks, and further save costs for owners.

03 More precise refrigerant  
and temperature control



By using high-precision electronic expansion valves and liquid level sensors, the refrigerant flow rate and container liquid level can be accurately controlled based on real-time load changes in the refrigeration system. Adopting high-precision temperature controller, the water temperature control accuracy is  $\pm 0.5^{\circ}\text{C}$ .

04 Wide operation, large  
cooling capacity



The entire unit can achieve a wide range of operation with 10% to 100% stepless adjustment, and the compressor series with different sizes can reach a minimum of 2%. A single unit can be equipped with up to 8 maglev compressors, with a maximum cooling capacity of 1600RT.

05 Integrated design,  
customized according to  
non-standard requirements



By designing a multi compressor system, the utilization rate of the entire heat exchange area can reach 100% during partial load operation, resulting in higher efficiency. The combination of large and small compressors enables more precise control of partial loads and higher load utilization efficiency.

# TECHNICAL DATA

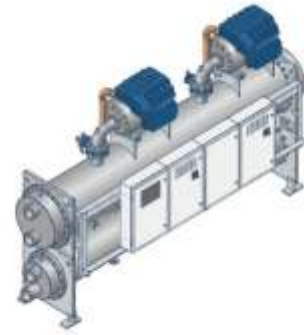

Product model		MGCW-65-1DB- EA06-CA06-GV	MGCW-80-1DB -EA08-CA08-GV	MGCW-125-1DC -EA12-CA12-SV	MGCW-150-1DE -EA15-CA15-SV	MGCW-200-1DG -EB20-CB20-HV	MGCW-250-2DC -EA25-CA25-SV	MGCW-300-2DE -EA30-CA30-SV	
Nominal cooling capacity	RT	65	80	125	150	200	250	300	
	kw	229	281	440	528	703	879	1055	
	kcal/h x 10 <sup>4</sup>	19.66	24.19	37.80	45.36	60.48	75.60	90.72	
Nominal power	kw	38	45	68	83	103	136	166	
Rated current	A	64	76	115	140	174	229	280	
COP	kw/kw	6.03	6.27	6.47	6.36	6.83	6.47	6.36	
GB IPLV	-	7.89	8.92	9.69	10.52	10.69	9.49	10.52	
Compressor	Type	Maglev oil-free variable frequency centrifugal compressor							
	Quantity	1	1	1	1	1	2	2	
Refrigerant	R134a								
The refrigerant throttle mode	Electronic expansion valve								
Power supply	AC380V/50Hz/3Ph								
Evaporator	Type	Flooded evaporator							
	Chilled water flow rate	m <sup>3</sup> /h	39	48	76	91	121	151	181
	Pressure drop	kpa	100	100	100	100	100	100	100
	Maximum working pressure	Mpa	1						
	Pipe diameter	DN	100	100	150	150	150	200	200
Condenser	Type	Shell and tube condenser							
	Chilled water flow rate	m <sup>3</sup> /h	49	60	95	113	151	189	227
	Pressure drop	kpa	80	80	80	80	80	80	80
	Maximum working pressure	Mpa	1						
	Pipe diameter	DN	100	100	150	150	150	200	200
Dimension	Length	mm	2400	2400	2400	2400	2800	4300	4300
	Width	mm	1400	1400	1500	1500	1600	1600	1600
	Height	mm	2000	2000	2300	2300	2450	2600	2600
Lifting weight	kg	1200	1800	2360	2460	2700	3700	3800	
Operating weight	kg	1300	2010	2550	2650	2900	4080	4180	

# TECHNICAL DATA

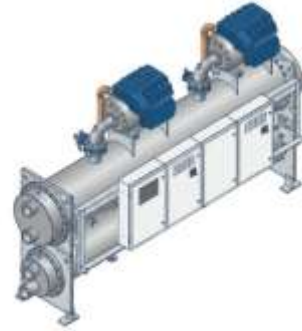

Product model		MGOW350-2DG-EA35-CA35-SV	MGOW400-2DG-EB40-CB40-HV	MGOW450-3DE-EA45-CA45-SH	MGOW500-2DEX1DG-EA50-CA50-SH	MGOW600-3DG-EB60-CB60-HH	MGOW700-2DEX2DG-EA70-CA70-SH	MGOW800-4DG-EB80-CB80-HH	MGOW900-2DEX3DG-EA90-CA90-SH	
Nominal cooling capacity	RT	350	400	450	500	600	700	800	900	
	kw	1231	1407	1583	1759	2110	2462	2814	3165	
	kcal/h x 10 <sup>4</sup>	106	121	136	151	181	212	242	272	
Nominal power	kw	193	206	248	275	309	387	412	485	
Rated current	A	326	348	419	465	522	653	695	820	
COP	kw/kw	6.38	6.83	6.38	6.39	6.83	6.36	6.83	6.52	
GB IPLV	-	10.58	10.69	10.58	10.47	10.69	10.52	10.68	10.72	
Compressor	Type	Magnetic suspension oil-free frequency conversion centrifugal compressor								
	Quantity	2	2	3	3	3	4	4	5	
Refrigerant	R134a									
The refrigerant throttle mode	Electronic expansion valve + hole plate									
Power supply	AC380V/50Hz/3Ph									
Evaporator	Type	Flooded evaporator								
	Chilled water flow rate	m <sup>3</sup> /h	212	242	272	302	363	423	484	544
	Water side pressure	kpa	100	100	100	100	100	100	100	100
	Maximum water side working pressure	Mpa	1							
	DN	200	200	250	250	250	300	300	300	
Condenser	Type	Shell and tube condenser								
		m <sup>3</sup> /h	262	302	340	378	454	529	605	681
	Pressure drop	kpa	80	80	80	80	80	80	80	80
		Mpa	1							
	Pipe diameter	DN	200	200	250	250	250	300	300	300
Dimension	Length	mm	4300	4300	4500	4500	4500	5400	5400	5400
	Width	mm	1600	1600	1900	1900	1900	2000	2000	2000
	Height	mm	2600	2600	1750	1750	1750	1900	1900	1900
Lifting weight	kg	4800	5240	6650	7775	8900	9400	9900	10750	
Operating weight	kg	5180	5630	7320	8525	9730	10265	10800	11350	

# Job References

S/N	Project( Chiller)	Tonage
1	15 Scotts , Singapore	800 Tons
2	OrchardPoint, Singapore	900 Tons
3	Tiong Ang Building , Singapore	450 Tons
4	Borgwarner Plant, Singapore	300 Tons

# Water Quality

Maximize your chiller’s lifespan and efficiency by maintaining superior water quality. Our integrated filtration and auto tube brushing systems work alongside your unit to protect against tube fouling and ensure peak performance

SAND FILTRATION SYSTEM



AUTOMATIC TUBE BRUSH SYSTEM

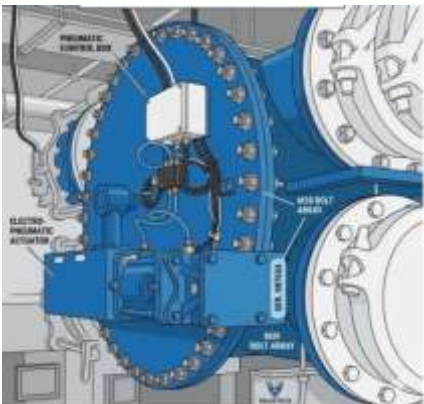

# About Us

---



## Singapore

ACMV Pte Ltd  
59Q Tuas South Ave.1 Singapore 637416 Tel: (65) 67733009 Fax:  
T: (65) 62805122; Email: [ekjcheng@acmvtech.com](mailto:ekjcheng@acmvtech.com)

## Malaysia

ACMV Technology Sdn Bhd  
48 ,Jalan Laman Setia 7/3, Persiaran Laman Setia, Setia Business Park,  
81550 Johor Baharu, Johor, Malaysia

## Indonesia

ACMV Technology  
Ruku YC Hub C20 Jalan Damai Foresta  
BSD Sampora Tangerang – Banten 15845